



AB-120 Announcer Console

### Description

The AB-120 Announcer Console is a compact desktop unit designed specifically for sports, live-event broadcasting and voice-over work. The ultimate broadcast quality tool for announcers and commentators, the AB-120 integrates all the inputs, outputs and controls necessary at the announce position, including intercom "Talkback", IFB and a silent "Mic Mute" button that provides noise-free "Cough" and "Mic on/off" switching.

The "no compromise" mic preamp ensures the highest broadcast quality audio from the announcer's microphone. A high-output stereo headphone amplifier guarantees talent can always hear both program audio and "cues" from the control room, even in the loudest of live sporting environments.

The AB-120 plugs into and draws power directly from most intercom and IFB systems, permitting an announce position to be located virtually anywhere, regardless of available AC power. Extremely flexible, the console is easily configured for practically any combination of audio sources, microphones, headsets or intercom systems, ensuring quality audio and powerful communications.

### On-Air Broadcast Quality

The AB-120 can be used with virtually any professional broadcast headset or separate microphone/headphone and always delivers broadcast quality line-level audio. A Jensen™ output transformer delivers up to -10dBu (with 20dB of headroom) into 600 Ohms, providing a properly balanced signal and reduces the possibility of ground loops, buzz or hum.

When locally powered, the AB-120 also provides phantom power for headsets with condenser microphones.

### Intercom Communications

Pressing the "Talkback" key momentarily switches the microphone output from "on-air" to the intercom channel.

The console can be configured so that intercom audio can be heard in the left ear, right ear or both, helping the talent to instantly identify the source.

The AB-120 connects to almost any professional audio system.

### Features:

- Broadcast quality mic preamp with Jensen™ output transfer
- Talent "Talkback" circuit automatically mutes Mic output to "air"
- Silent "Mic Mute" button for "Cough" and "Mic on/off" functions
- Easily adapts for use with any mic or headset
- Quick and simple set up using standard XLR mic cable
- Wide range, high-output headphone amplifier
- Binaural headset output allows talent to hear stereo program, IFB and/or intercom
- IFB input accepts either unbalanced program or powered IFB
- Interfaces with intercom and IFB systems
- Powered by intercom, IFB line or external DC source



# Clear-Com Encore™

## AB-120 Announcer Console

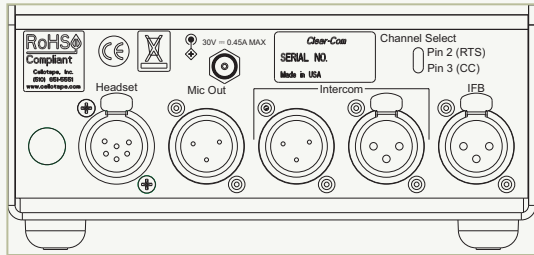

AB-120 Back Panel

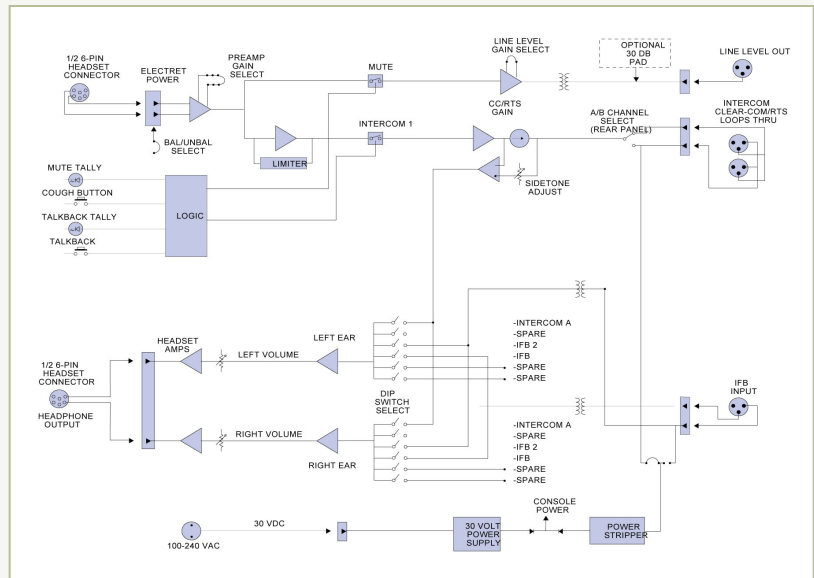

AB-120 Block Diagram

### Technical Specifications:

dBu is an absolute measurement. 0 dBu is referenced to 0.775 volts RMS.

#### Headset Microphone Input

Input Type: Dynamic, Electret  
 Input Impedance: 1K Ohms  
 Max Input Level: -60 dBu to -40 dBu switchable

#### Headset Output

Load Impedance: >= 4 Ohms  
 Output Impedance: 47 Ohms  
 Output Limiter Threshold: -4 dBu, ± 3 dB  
 Max Output Level Before Distortion: -4 dBu

#### Party-line Output

Off Noise: <-80 dBu  
 Output Impedance: >10K Ohms  
 Maximum Output: -4 dBu

#### Party-line Input

Maximum Level Before Clipping: +3 dBu  
 Sidetone Null Capability: >25 dB

#### Frequency Response

Dynamic Mic - Party-line: 40Hz - 22KHz, ± 3 dB  
 Dynamic Mic - Line Out: 20Hz - 22KHz, ± 3 dB  
 Dynamic Mic - 4-Wire Out: 100Hz - 22KHz, ± 3 dB  
 IFB Input - Headset Out: 100Hz - 22KHz, ± 3 dB  
 Party-line - Headset Out: 150Hz - 22KHz, ± 3 dB

#### Max Distortion

Dynamic Mic - Party-line: <0.1%  
 Dynamic Mic - Line Out: <0.05%  
 IFB Input - Headset Out: <0.5%  
 Party-Line - Headset Out: <0.1%

#### Noise

Dynamic Mic - Party-line: <-75 dBu  
 Dynamic Mic - Line Out: <-85 dBu  
 IFB Input - Headset Out: <-65 dBu  
 Party-Line - Headset Out: <-65 dBu

#### Max Gain

Dynamic Mic - Party-line: 41 dB ± 3 dB  
 Dynamic Mic - Hot Mic Out: 40 dB ± 3 dB  
 IFB Input - Headset Out: 40 dB/22 dB (switchable) ± 3 dB  
 Party-line - Headset Out: 34 dB ± 3 dB

#### Rear Panel Connectors

Headset: XLR-6F  
 Microphone Out: XLR-3M  
 Intercom: 2 XLR-3 (male and female loop through)  
 IFB: XLR-3F  
 Power: 2.1mm jack

#### Front Panel Controls and Indicators

- (1) Mute button
- (1) Mute indicator LED (red)
- (1) Talk back button
- (1) Talk back indicator LED (green)
- (1) Interrupt level control
- (1) Non-Interrupt level control

#### Power

Intercom/IFB Voltage: 25 - 30 VDC  
 Current: 100mA idle, 120mA max  
 DC Adapter: 100 - 240V  
 Voltage: 30V @ 0.5A

#### Environmental

32° - 122° F (0° - 50° C)

#### Dimensions

6.0 in W x 3.0 in H x 8.0 in D  
 (152 mm x 76 mm x 203 mm)

#### Weight

2.0 lbs. (0.9 kg)

#### Notice About Specifications

While Clear-Com makes every attempt to maintain the accuracy of the information contained in its product manuals, that information is subject to change without notice. Performance specifications included in this manual are design-center specifications and are included for customer guidance and to facilitate system installation. Actual operating performance may vary.

[www.clearcom.com](http://www.clearcom.com)

**Americas & Asia** 850 Marina Village Parkway, Alameda, CA 94501 USA Tel: +1.510.337.6600

**Europe, Middle East & Africa** 7400 Beach Drive, IQ Cambridge CB25 9TP UK Tel: +44 1223 815000

**China** Rm 706, Tower B, Derun Building, YongAn Dongli A No.3, Jianwai Ave, Chaoyang District, Beijing, China 1000223 Tel: 008610-8528-8748

**Canada** Clear-Com Research, 1440 Hocquart Street, Suite 221, St.-Bruno, Quebec J3V 6E1, Canada Tel: +1.450.653.9669

©2009, Vitec Group Communications, LLC. All rights reserved. ©Clear-Com is a registered trademark of The Vitec Group plc.